

MCR ALPE - DUBBELE DRAAIDEUR Ei<sup>2</sup>-60  
 Hoekkozijn (standaard) gelaste scharnieren (standaard)

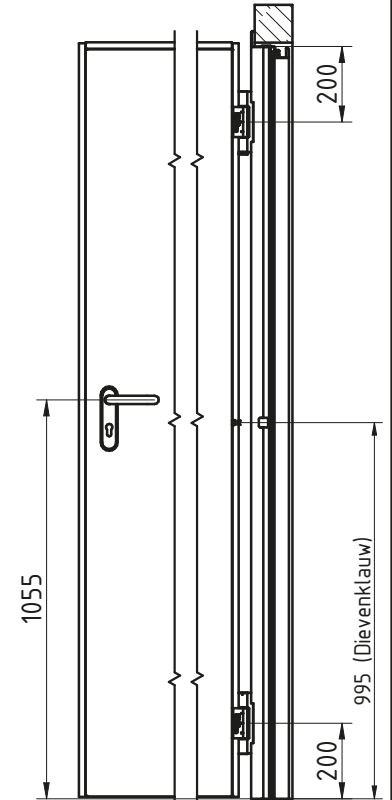

DÉTAIL A

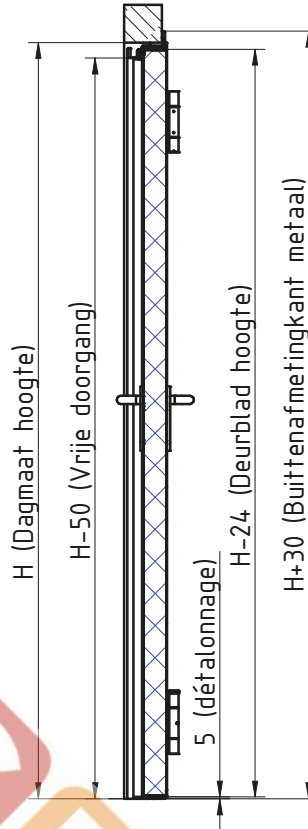
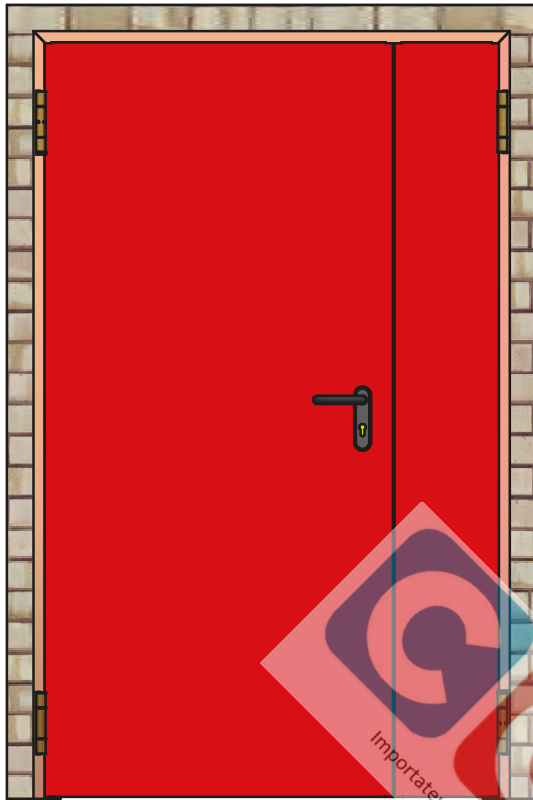
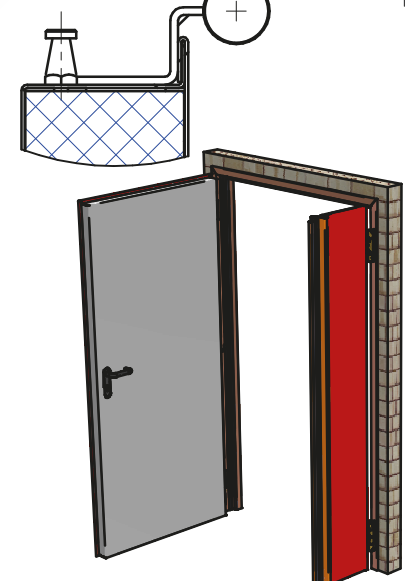
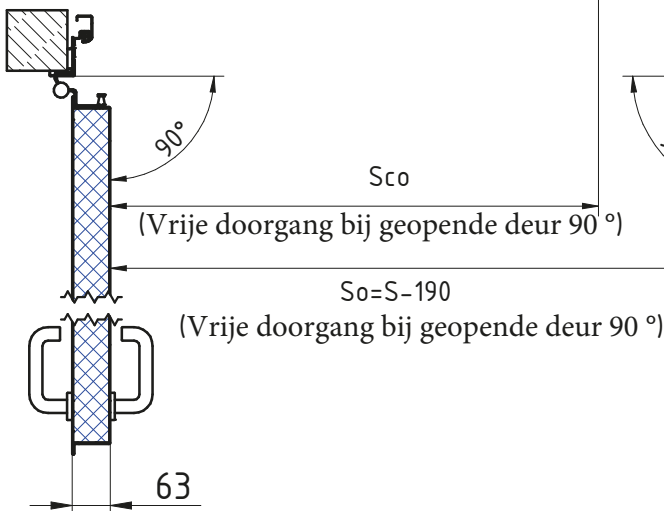
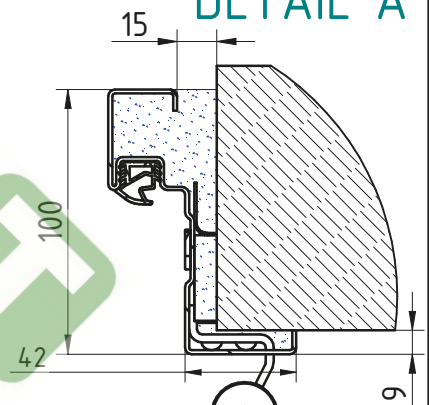
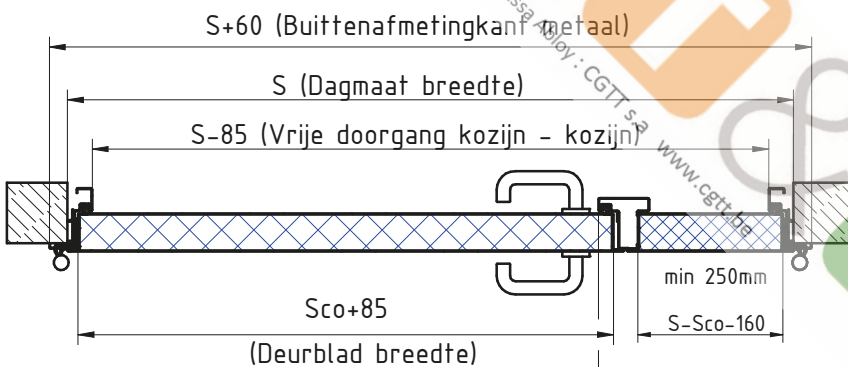

\*\*Zie fiche over inkerven van beton